

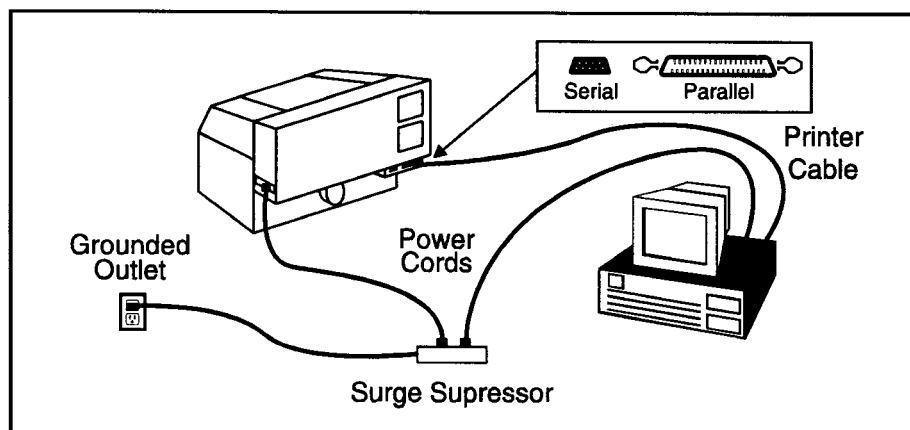

# GRAVOGRAPH NEW HERMES

## Laser Installation

1. The running of today's laser engraving systems, all in all, is a fairly simple process. Most systems manufactured today are made as Class 1 enclosed units and were made with simplicity in mind. The most important thing is to follow all of the original manufacturer's recommendations when running your system. This will allow you to get maximum results with minimal problems.
2. Pre-Plan  
Prior to getting your system in-house, you will want to do certain things to ensure the safe and efficient running of your system. First, pick a spot for your system. These systems run clean and can be operated in most environments. However, it does pay to pick a place that is relatively dust free, humidity free and not exposed to continuous vibrations or otherwise loud noises. Ambient temperatures of 60 to 80 degrees Fahrenheit are generally recommended. Also, make sure that you have adequate space not only for the system, but also for the PC and the storage of product, cleaning and finishing supplies. Additionally, you will want to invest in a fire extinguisher that is made for electrical fires.
3. Installation  
If you've ever installed a printer on your PC, then you know how to install a laser engraving system. Find the manual first and you can follow along. Again, it is important to follow the manufacturer's recommendations when unpacking and setting up your system.



Proper operating conditions are vital to a safe and productive environment. Choose the right location to plugging in the connectors. You will get a driver with your machine that is installed into your computer as a new printer driver. You will then connect your system to your PC using a parallel printer cable. Stick with one that is less than 10 feet. You will also want to hook up your exhaust fan to the system so that all vaporized materials are exhausted to the outside.

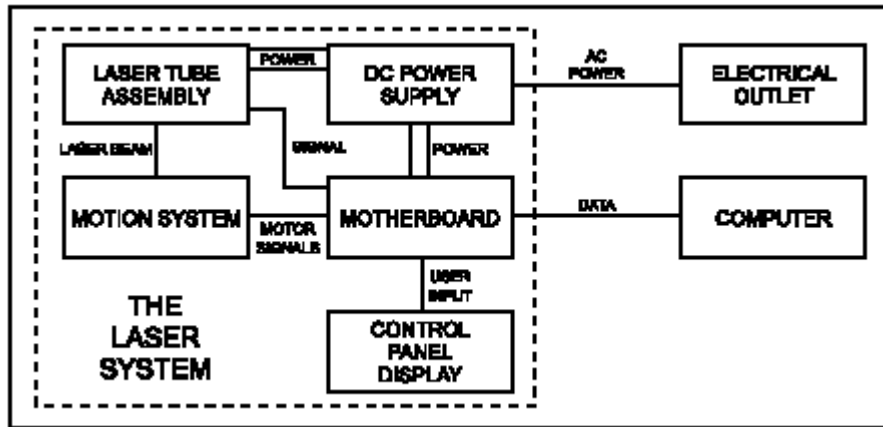

## WARNING

Please follow the guidelines below. Failure to provide the proper operating environment can cause damage to the laser system as well as your computer.

- Room temperature must remain between 65 and 85 degrees Fahrenheit or between 17 and 27 degrees Celsius.
- Humidity levels must be less than 70% or where the temperature is at least 10 degrees above the dew point temperature. Dew formation can electrically short out the laser system and/or your computer and is very dangerous.
- Avoid dusty and dirty air environments. Keep the laser system isolated from any type of sandblasting, sanding equipment, and other machinery that produces airborne particles. Install the laser system in an office type environment.
- Avoid small, enclosed, non-ventilated areas. Some materials, after laser engraving or cutting, continue emitting fumes for several minutes after processing. Having these materials present in a confined, unventilated room can contaminate the room.
- Make sure that your electrical outlet is capable of providing the proper voltage, frequency and amperage that this system requires. Noisy or unstable electricity as well as voltage spikes can cause interference with the electronics of the laser system. Connect the laser system to a dedicated electrical line if this is a problem in your building.

•The electronics of the laser system has built-in surge suppression. However, it is a good practice to plug the laser system into a high quality surge suppressor and then plug the surge suppressor into a properly grounded outlet.

## WARNING

•**Never remove the ground lead to the electrical cord and plug the system into a non-grounded outlet.** This is very dangerous and can lead to a severe, if not fatal, electrical shock. Always plug the system into a 3 prong grounded outlet.

•If electrical power fluctuations, brown outs, or constant power outages are a problem in your area, an electrical line stabilizer, UPS (Uninterruptible Power Supply), or backup generator might be required. If installing any of these devices, make sure that they meet the electrical requirements of the laser system.

•If there is any type of electrical problem present, please contact a locally licensed electrical contractor to correct the problem. Repairs to the laser system will **NOT** be under warranty if the laser system is damaged by an improper or incorrect electrical supply as well as voltage spikes and surges. It is your responsibility to provide a suitable electrical supply.

• Choose a location which provides the shortest and most direct path to the exhaust ductwork (not provided).

• Have a worktable or storage area next to or nearby the laser system. This prevents the operator from using the system as a table or storage facility.

• Do not move, push, lean on, or jar the laser system while it is engraving. The material you are engraving can shift and produce unsatisfactory results.

• If planning to connect the laser engraving system to a computer through the parallel port, choose a location where the computer can be placed within 10 feet of the machine since this is the maximum recommended parallel cable length.

• If connecting an additional laser system or other printer to the same computer, we recommend the installation of an additional parallel port into the computer. **Never connect the laser system through a manual switch type A/B switch box.** This creates electrical noise, which can cause an engraving problem or can damage the laser system and/or the computer's electronics. **DO NOT** use a manual A/B type switch box. This creates electrical noise, which can cause an engraving problem or can damage the laser system and/or the computer's electronics.

•**Never use any device that is installed between the computers parallel port and the parallel port of the laser system such as a ZIP drive or parallel port CD-ROM drive.** This can not only damage the laser systems electronics but it usually will not work. Again, install an additional parallel port for other peripheral devices.

#### 4. Ready to Engrave

At this point, no doubt you are anxious to get started, so pick some material. At first, I would pick something that you don't mind seeing destroyed as it is strictly experimental time. You can choose any artwork. However, first make sure that you set up your table size in your graphics program to match the table size of your machine. This will ensure that you positioning is not a problem. Once your artwork is what you want, set your power, speed, and resolution. Go ahead and use the recommendations in your manual. You will quickly learn what settings suit you and your jobs the best.

#### 5. Getting over the Learning Curve

No doubt, your learning curve will provide some challenges for you. Your manual is a great resource. It is something you will want to read and then have available as a reference tool. It will guide you through installation, operations, maintenance and safety issues, as well as provide troubleshooting assistance and recommendations for your settings. Additionally, it is important to know whom to call when you are truly stuck. Many problems are solved over the phone, via e-mail and over the Internet with the technical support staff of the manufacturer of your system. Replacement parts are shipped out as needed and service techs assist customers with the installation of new parts. Manufacturers are also using websites more and more to provide technical information for their customers. There are also other websites as well as trade journals available that regularly provide tips and techniques for laser engravers. Additionally, seminars are available at industry trade shows that provide education for both beginning and advanced users. The more established companies also provide continuing education classes to help you expand your knowledge and your business.

#### 6. Conclusion

Don't let the technology scare you. By investing a little time and effort, in no time at all, you will be producing laser engraved items that impress even the most finicky customer. And don't forget, learning is a lifelong process. By keeping abreast of current trends, processes, options and new materials, you can continue to provide cutting edge products for your customers for years to come.